



3-Dimensional Integrated Circuit for Cellular Automata

December 4, 2009

James Harmon

Dissertation Advisor: Payman Zarkesh-Ha



Overview

- Research Description
 - 3-D Integrated Circuit Technology (Tezzara[®])
 - Cellular Automata (CA)
- Design
- Schedule
- Status
 - Tools
 - Layout
 - External Information
- Testing



Research Description – 3-D Integrated Circuit Technology (Chartered)

- Chartered Semiconductor Manufacturing Ltd.
 - 130nm
 - 5mm x 5mm Die
 - 6 Metal
 - 1.5V Logic
 - 2.5V Input/Output





Research Description – 3-D Integrated Circuit Technology (Tezzaron®)

- Tezzaron® Semiconductor Final Configuration

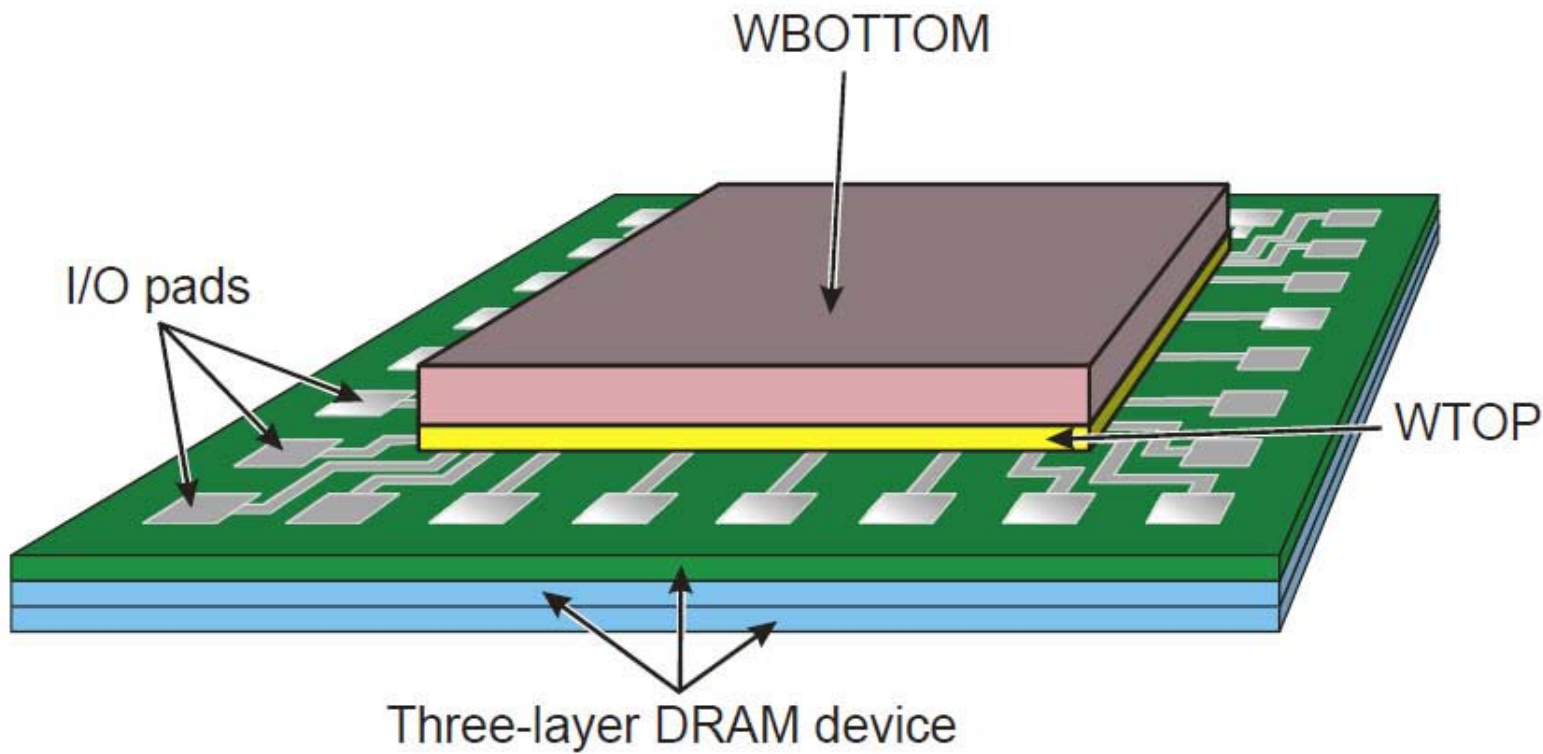



Research Description – 3-D Integrated Circuit Technology (Tezzaron[®])

- Tezzaron[®] FaStack[™] Process

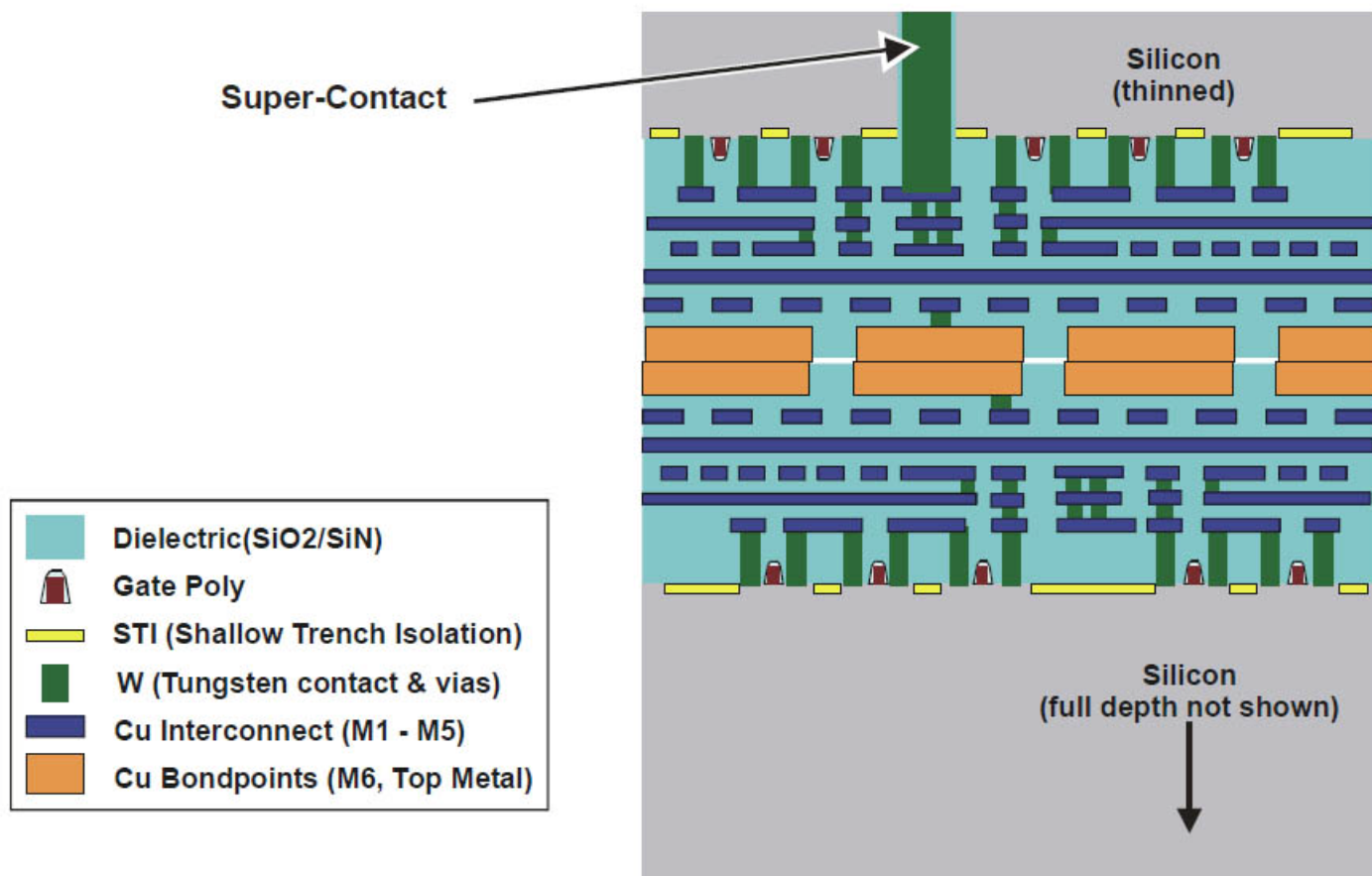



Research Description – 3-D Integrated Circuit Technology (Tezzaron[®])

- Tezzaron[®] FaStack[™] Process

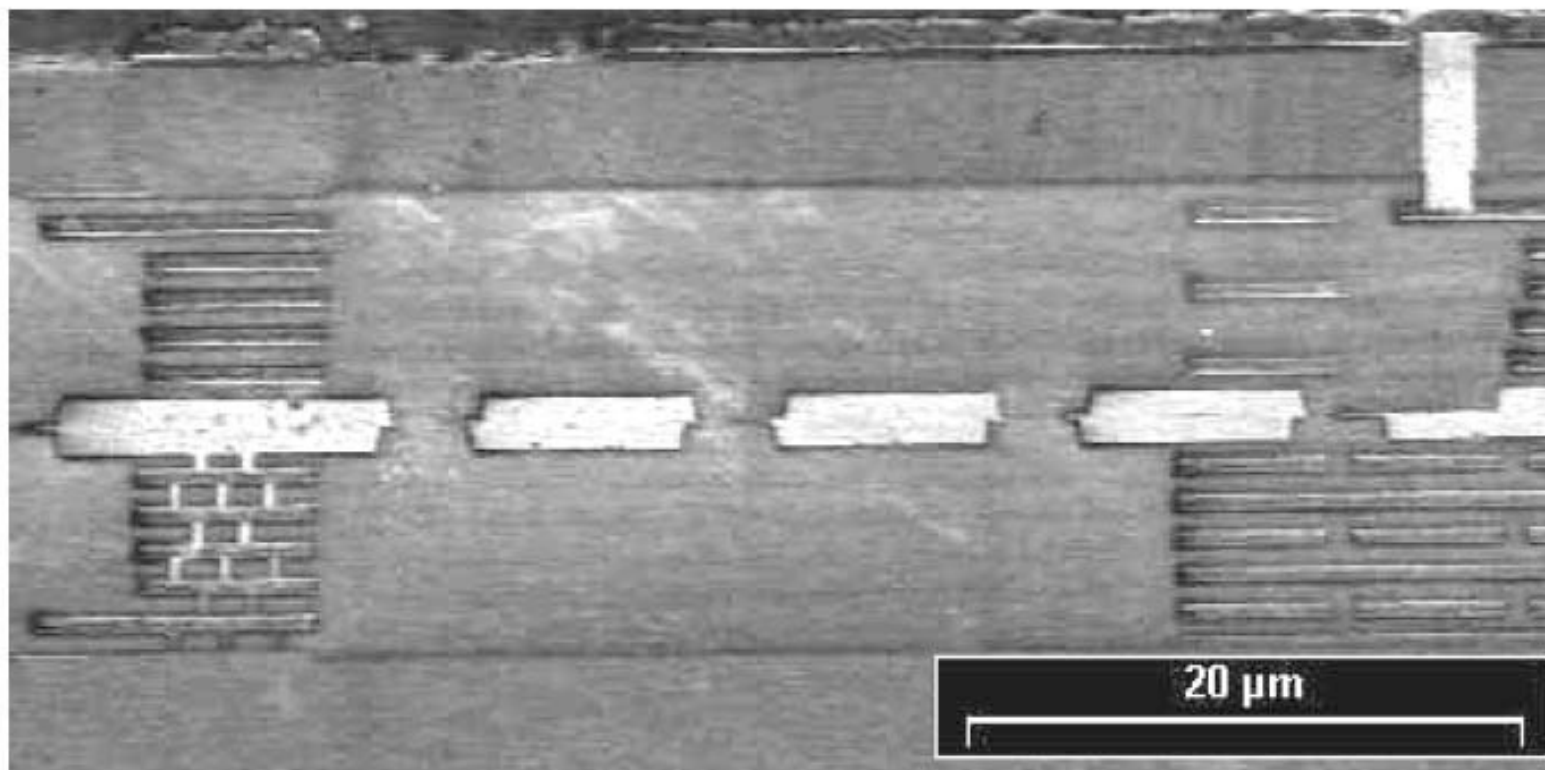



Research Description – Cellular Automata (CA)

- Two-State (Binary) Cellular Automaton

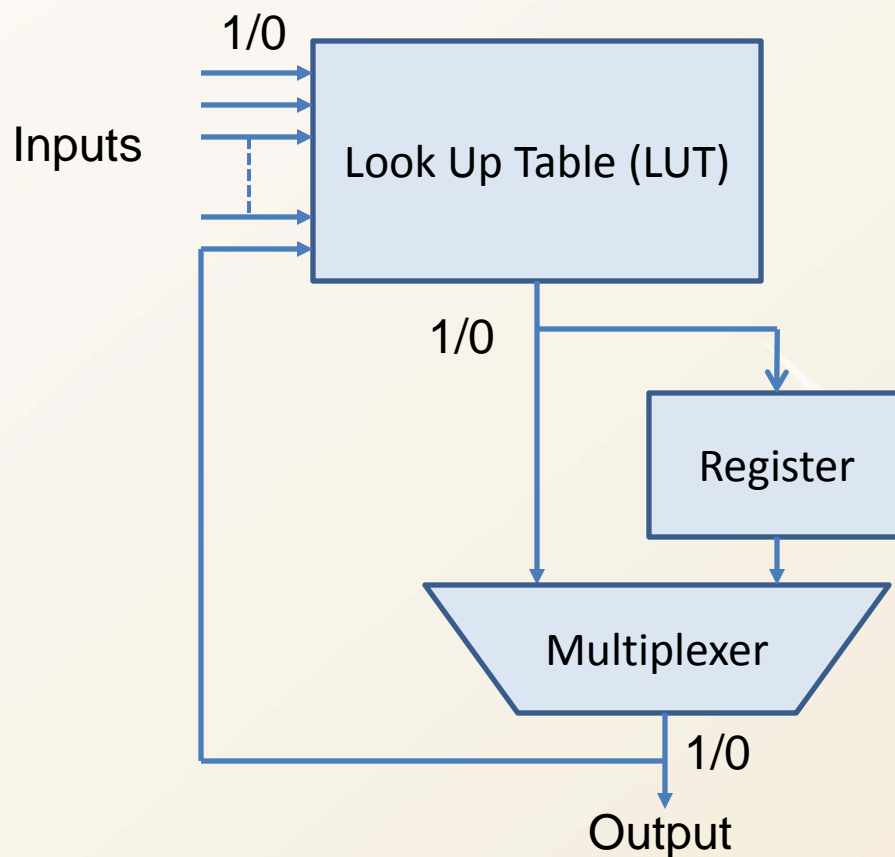



Planar CA Architectures

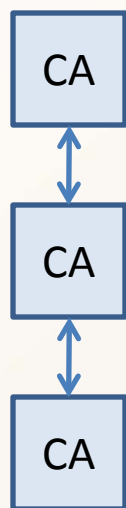

Linear
3 Neighbors
8 Patterns

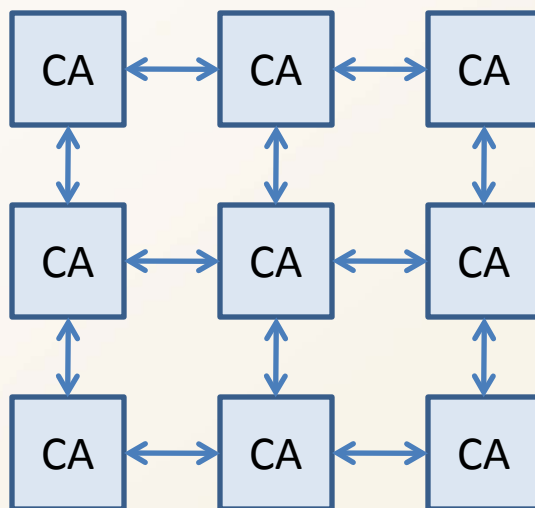

Orthogonal
5 Neighbors
32 Patterns

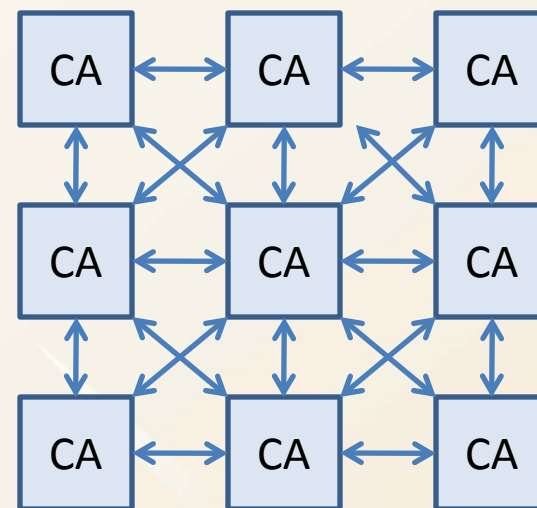

Adjacent
9 Neighbors
512 Patterns



3-Dimensional CA Architecture

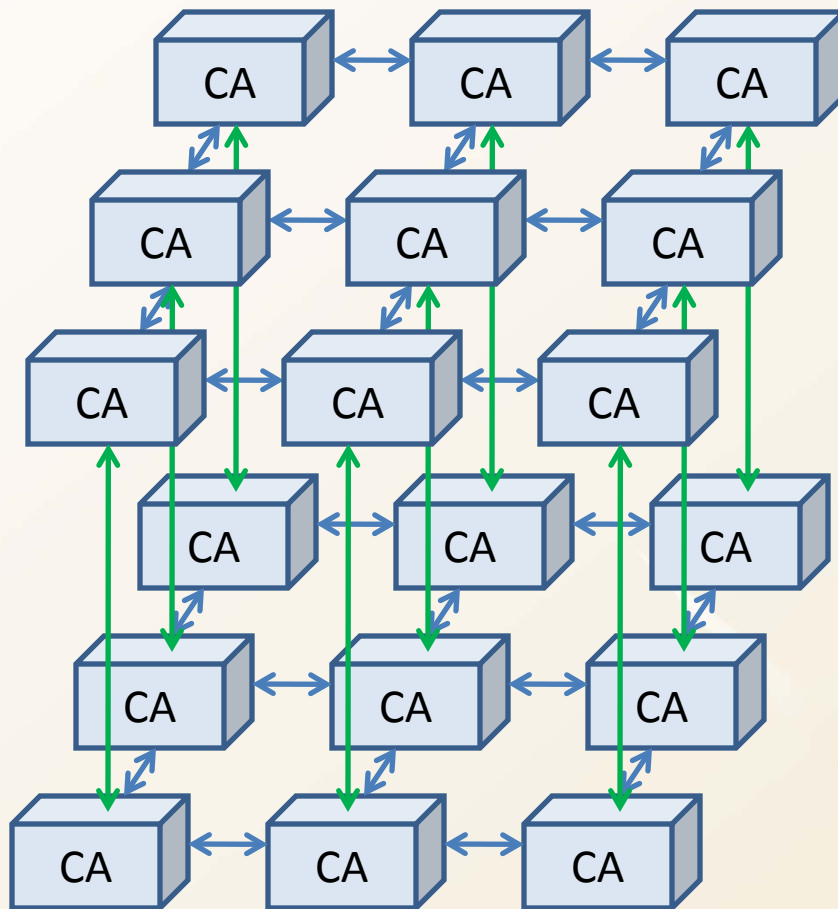

6 Neighbors
64 Patterns



CA Design

- Lookup Table
 - 64 D Flip-Flops with 64:1 Multiplexer (6 Selector Inputs)
 - Serial Programming Connection of Flip-Flops
- Register
 - D Flip-Flop
- Final Multiplexer
 - D Flip-Flop for Programming in series with LUT
 - 2:1 Multiplexer



D Flip-Flop

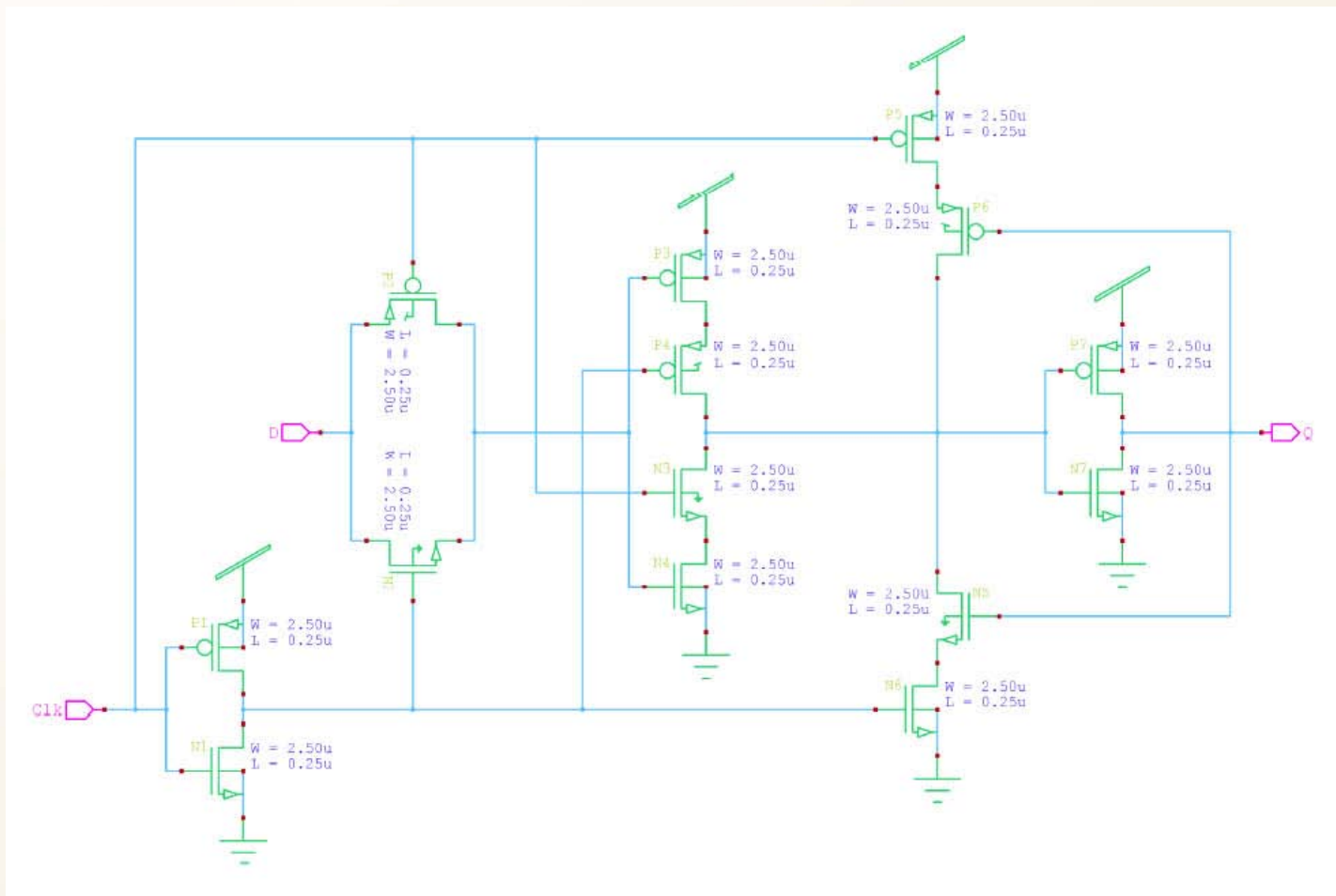



Schedule

- System Design July – August 2009
- Schematic Design August 2009
- Tool Integration August – November 2009
- Layout October 2009 – February 2010?
- Mock Tapeout 45 Days After Top Metal Specification
- Tapeout 60 Days After Top Metal Specification
- Fabrication 20 Weeks February – July 2010?
- Mounting July – August 2010?
- Testing August – November 2010?
- Report/Dissertation December 2010



Tools

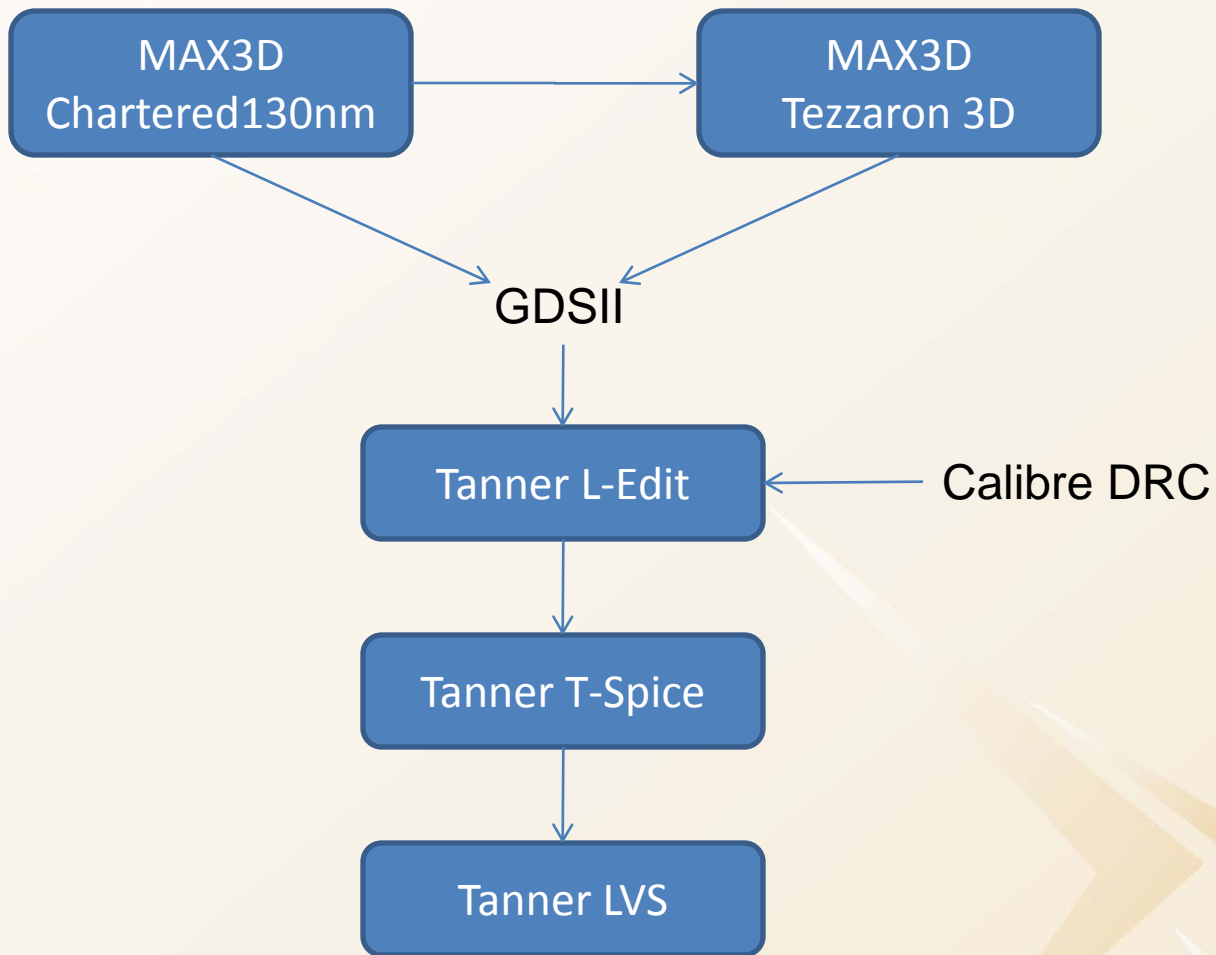



Tool Status

- Currently Using
 - Max3D with both technologies
 - Max3D GDSII output
 - L-Edit GDSII read
 - T-Spice simulation
 - Layout versus Schematic (LVS)
- Not Used Yet
 - Calibre[®] Design Rule Check (DRC)



Layout

- Layout is performed with Micro Magic Max3D editor
- Final tapeout is two GDSII files
 - UNM_left
 - Connects to UNM_right through Metal 6
 - Connects to Memory and I/O using Through Silicon Vias (TSVs) to Back Metal that is bonded to Memory
 - UNM_right
 - Connects to UNM_left through Metal 6
 - Flipped right-to-left and placed on top of UNM_left

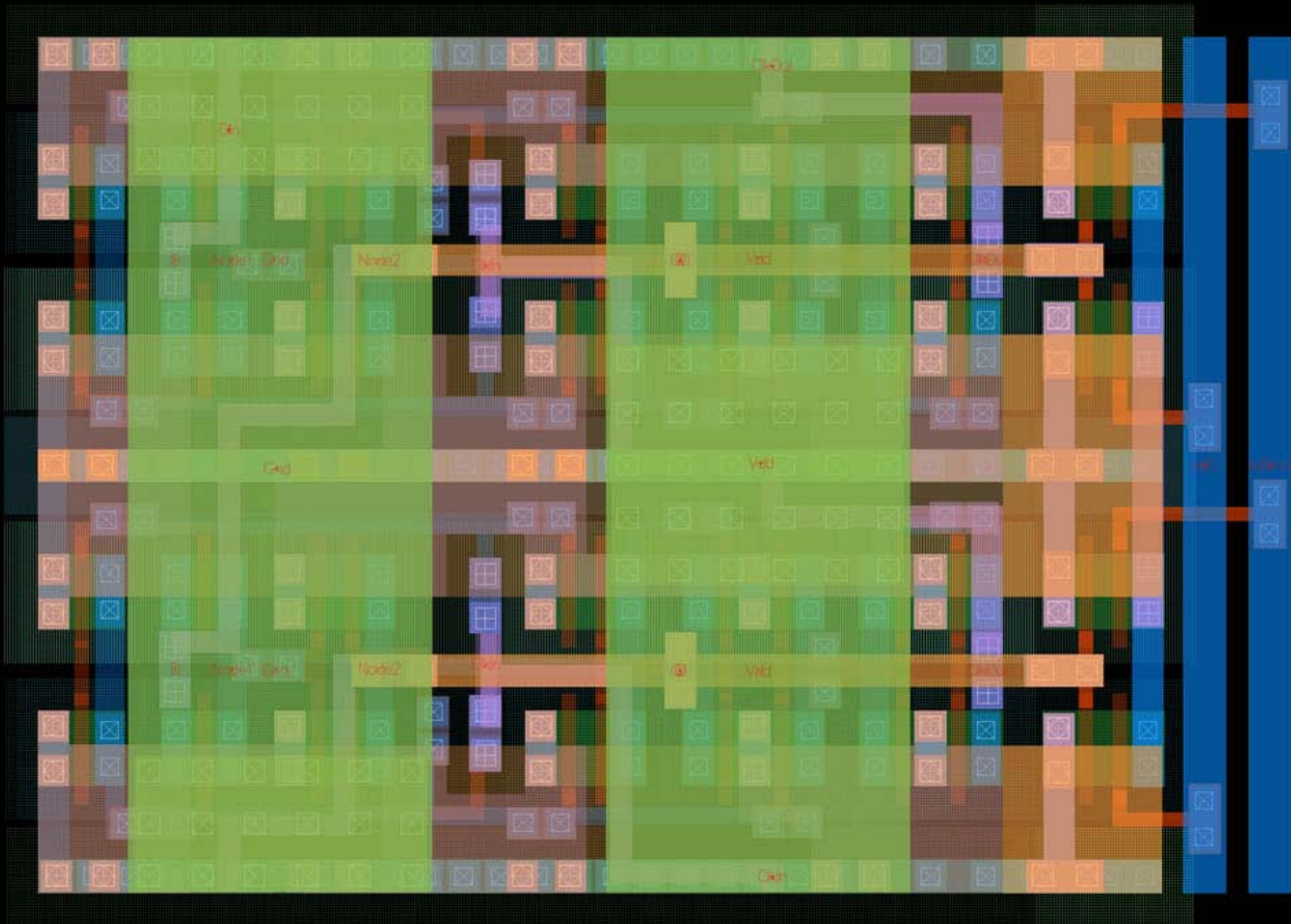

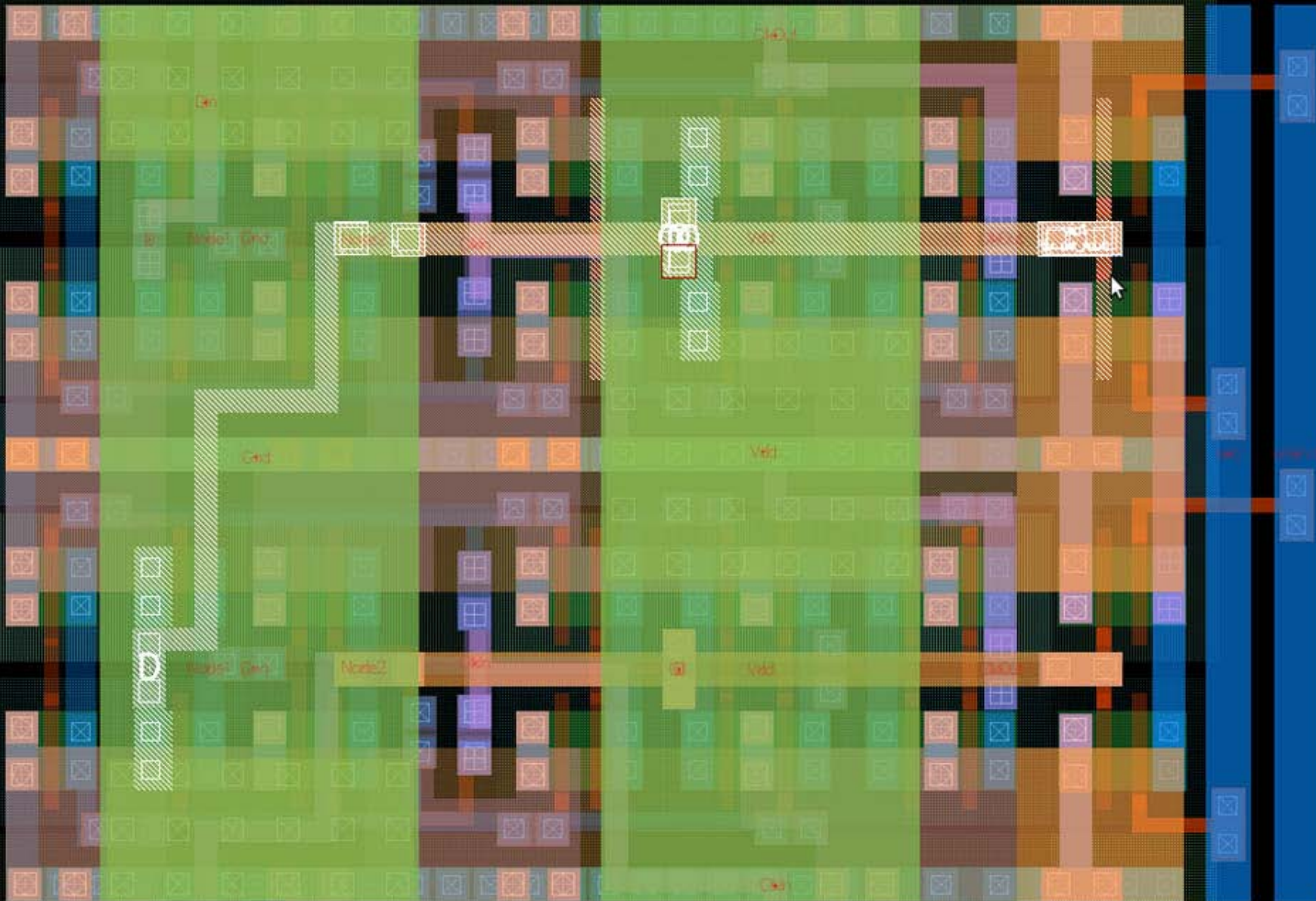

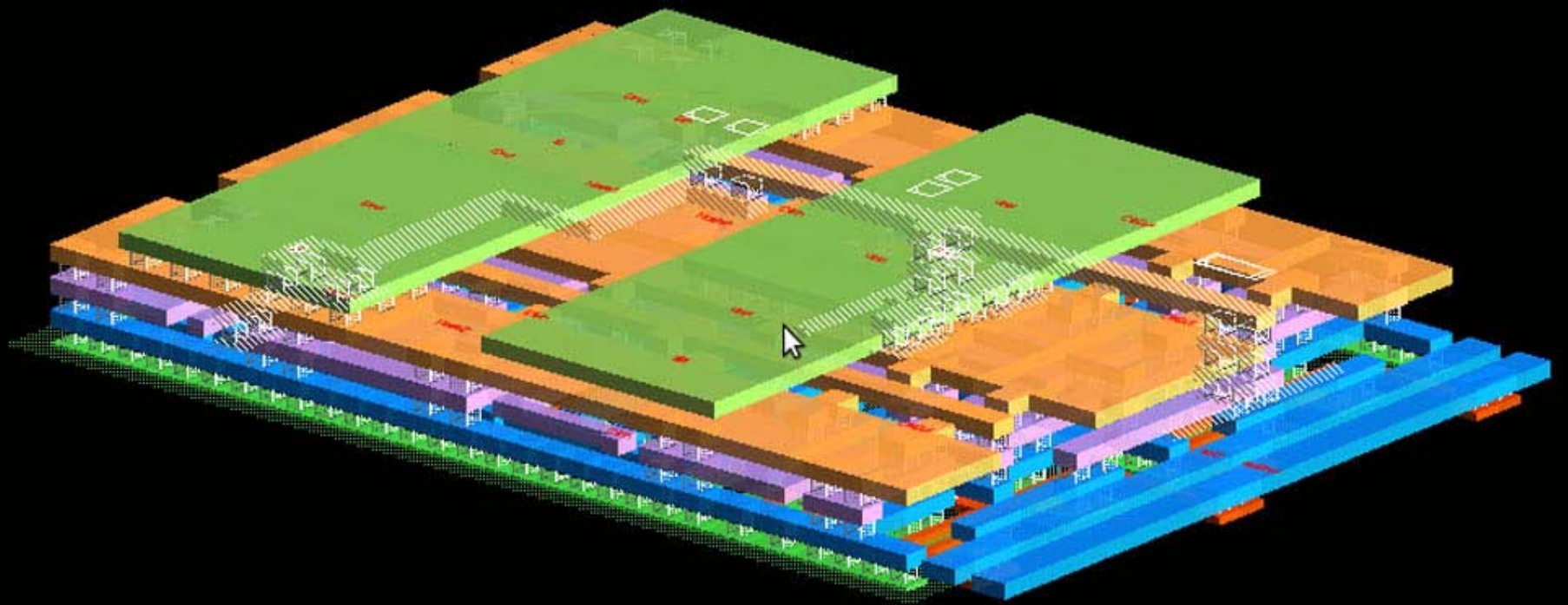

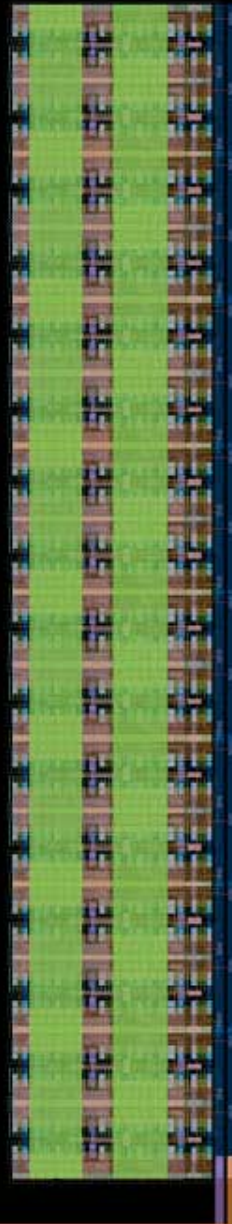
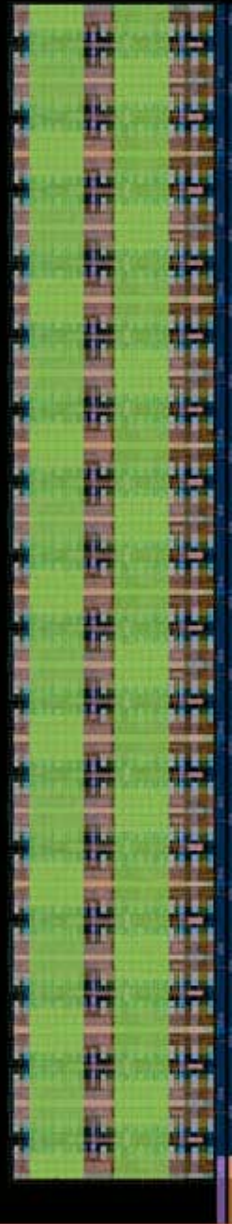
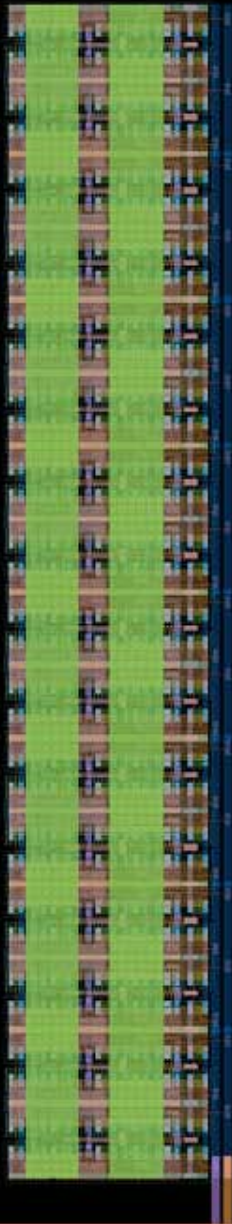
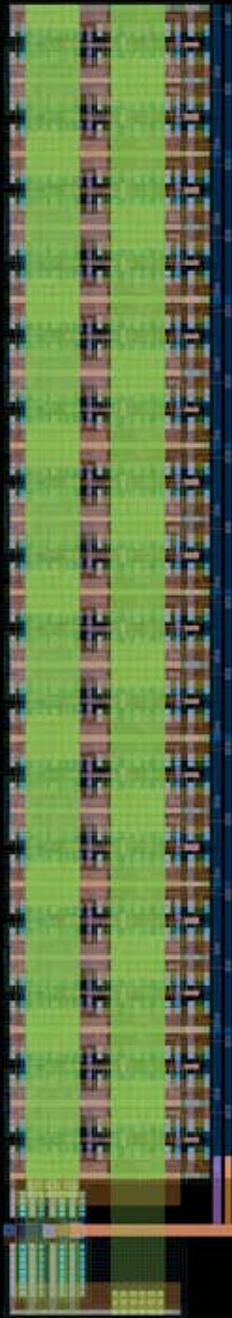

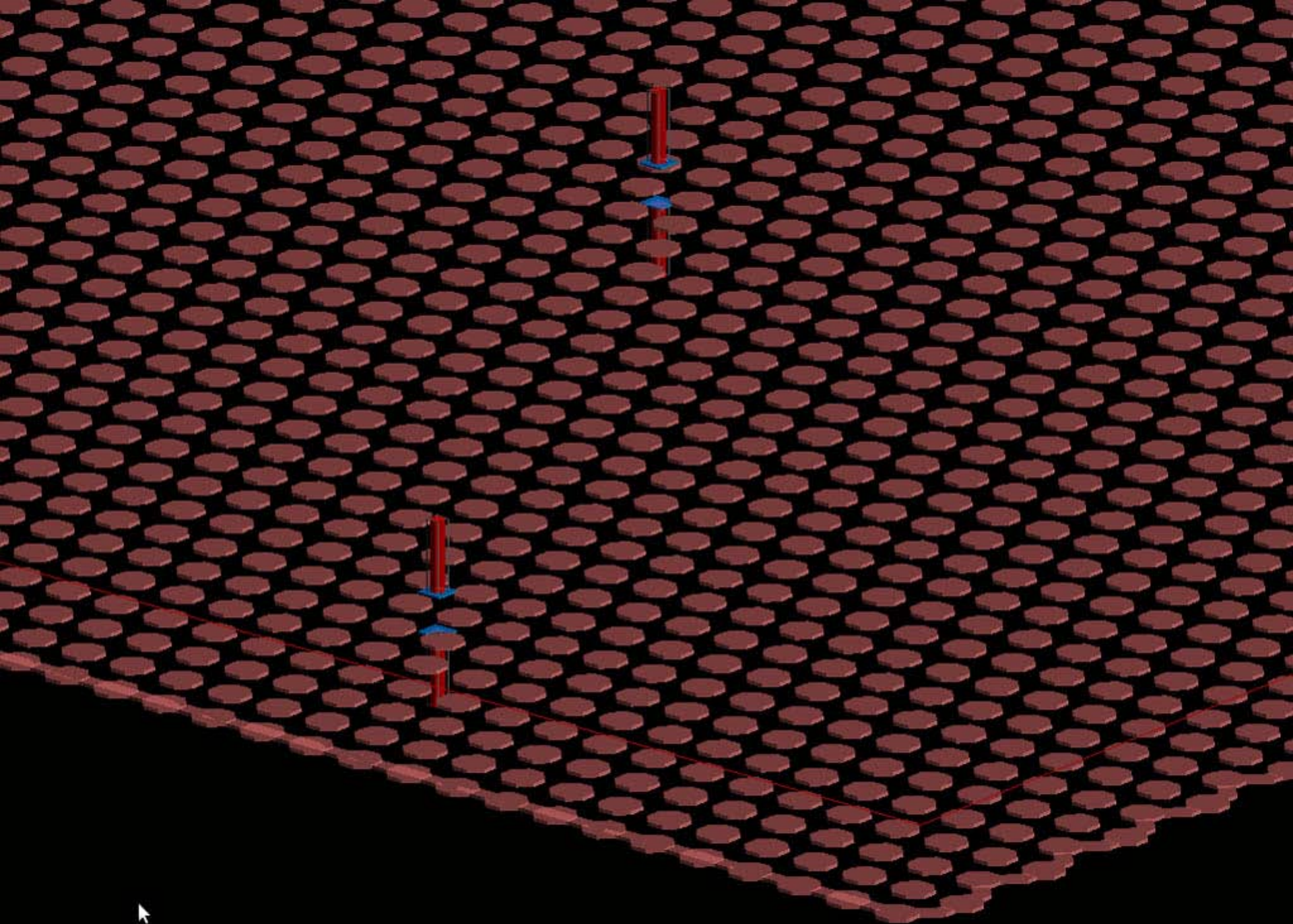

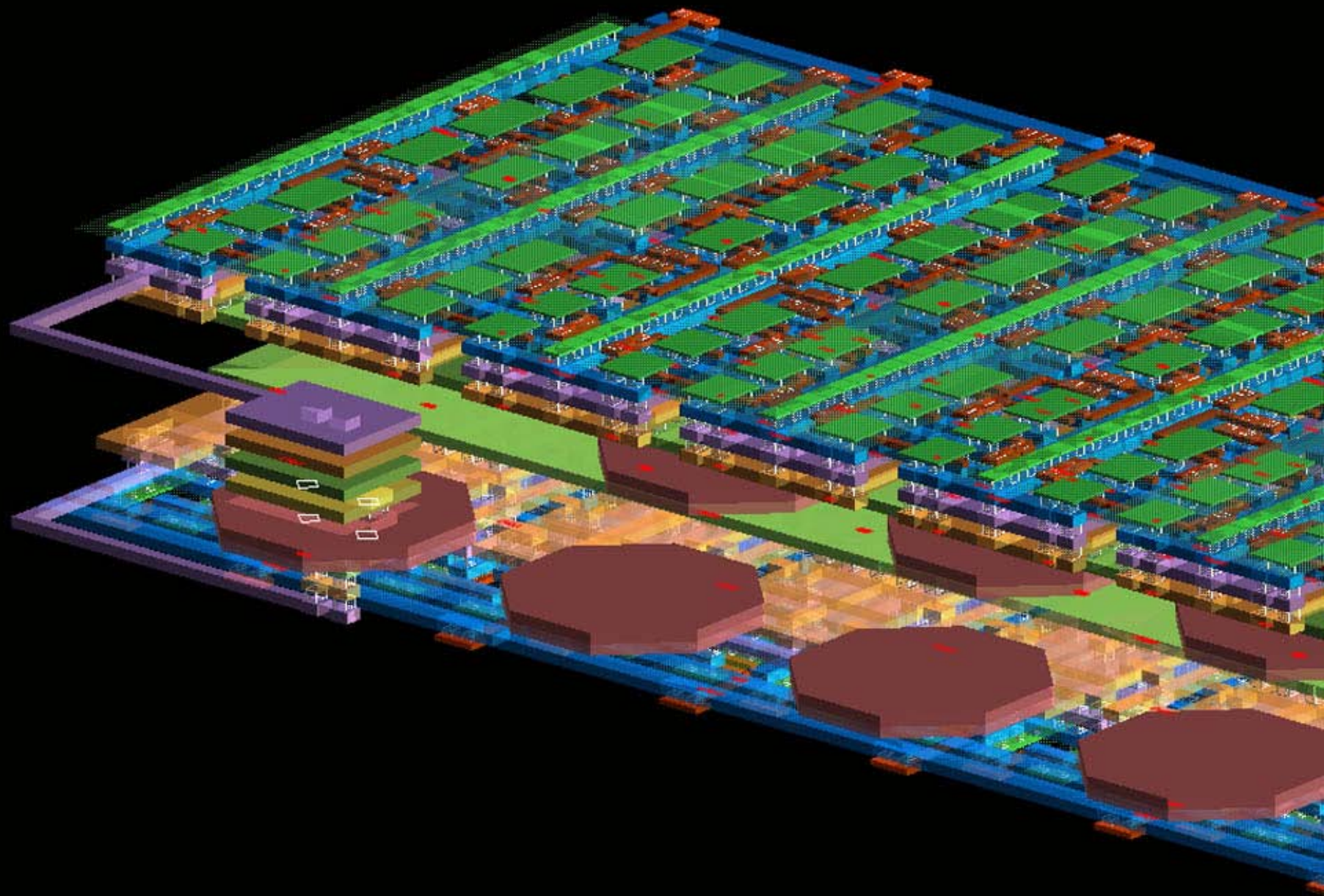

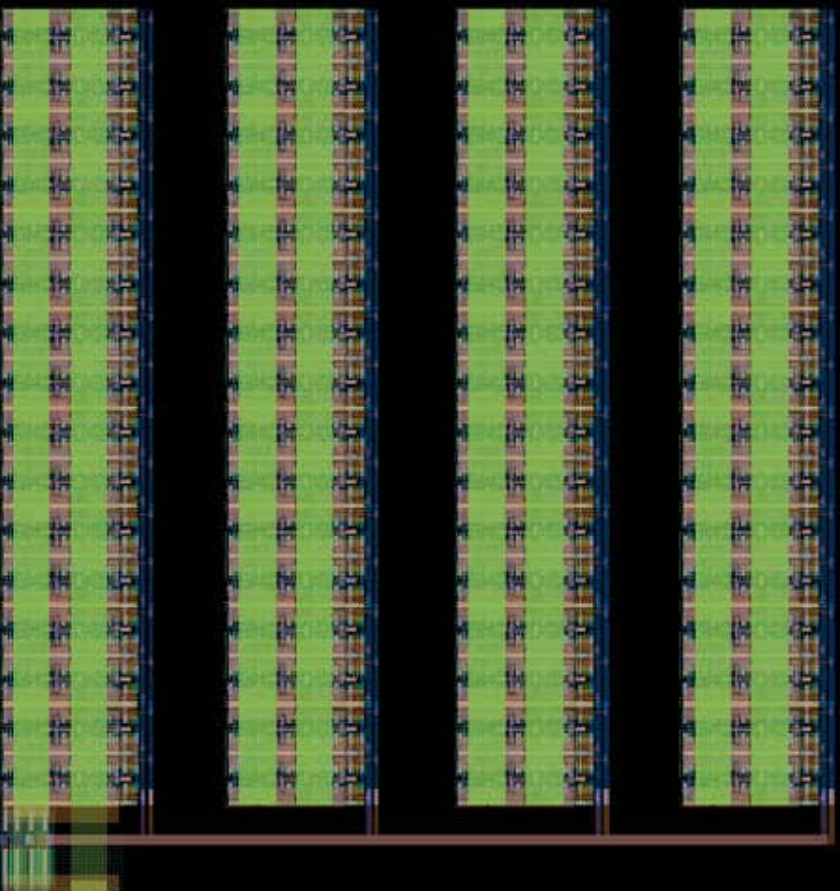

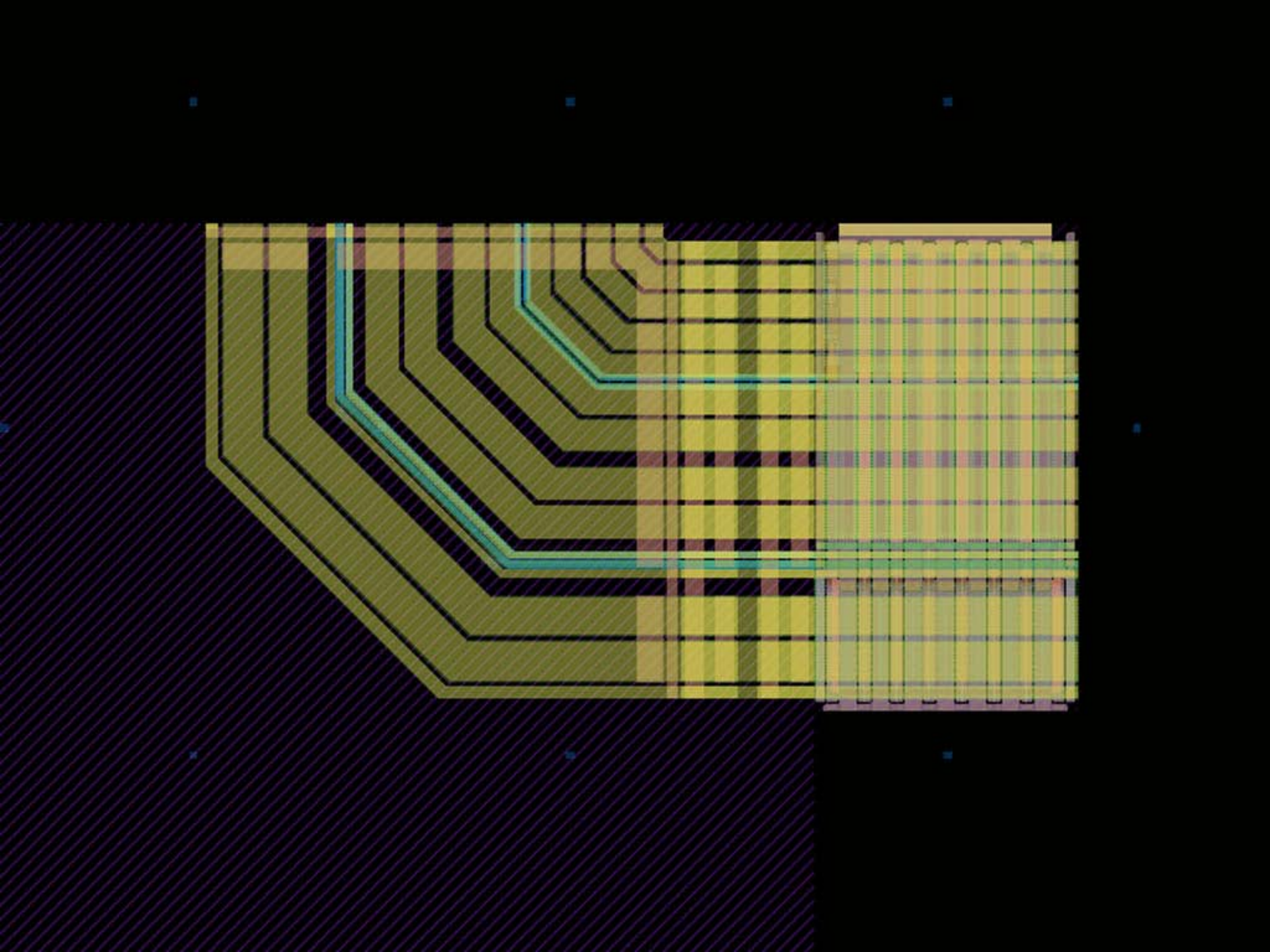

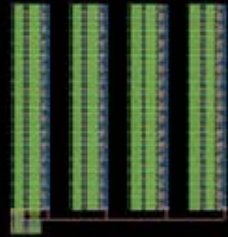
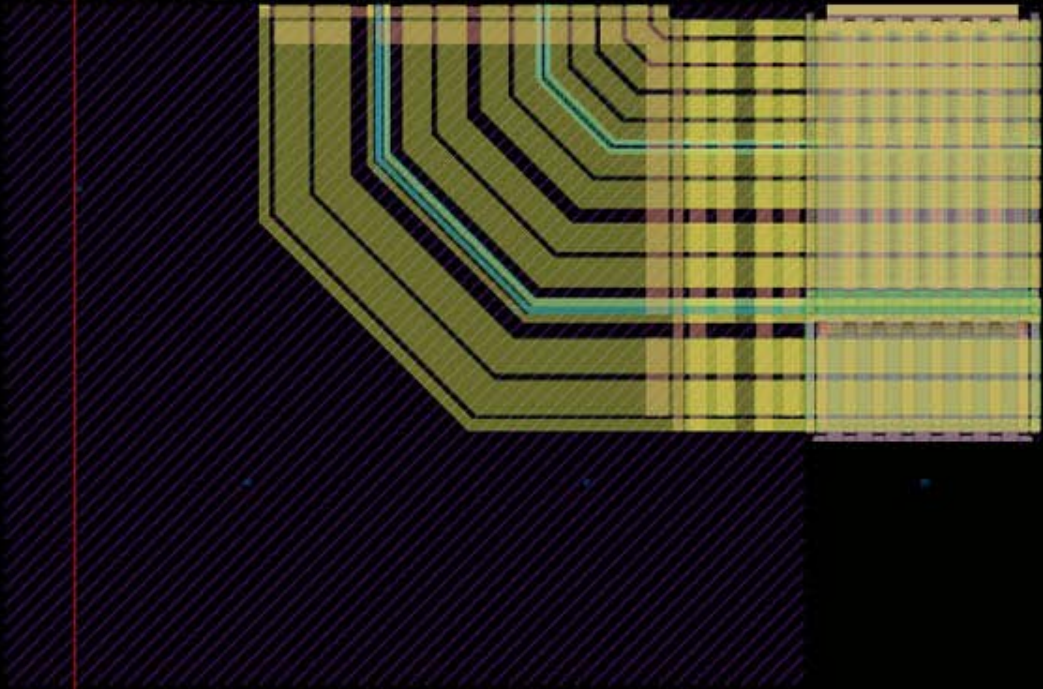

SV_tile5mmx5mm

SV_tile5mmx5mm_0





External Information Status

- Design Guidelines #6 Received
- SDK #6 with Patch 1 Received
- Top Metal Pattern Received
 - Communication between our two circuits
- Back Metal and Connection to Memory/Pads
 - Should be released soon
 - Tapeout 60 days after release (inc. holidays and weekends)
 - Quick Look Tapeout 45 days after release
 - Fab 20 weeks after tapeout



Testing

- Simulation
 - Verify test patterns
- Testbed
 - Programming
 - Run/Monitor Tests
- 3D CA
 - Operational Test
 - Functional/Application Tests



References

- MPW 100109 Design Guide, Revision 6, Tezzaron[®] Semiconductor, 4 November 2009, Available from MPW FTP Site
- FaStack Process Details, Revision 2, Tezzaron[®] Semiconductor, August 2009
Available at
http://tezzaron.com/technology/PDF/FaStack_Technology_2_0.pdf



Questions?

