



Self Healing Memory stack

Naveen Purushotham
Graduate student ECE



Self Healing Memory stack

- Idea is to build a robust system consisting of a stack of memory that is enabled with the capability of self healing
 - Have a contiguous memory map of the memory modules that serve a set of clients.
 - Retrieve the data lost in the spoiled memory module and restore it.

Self Healing Memory Stack

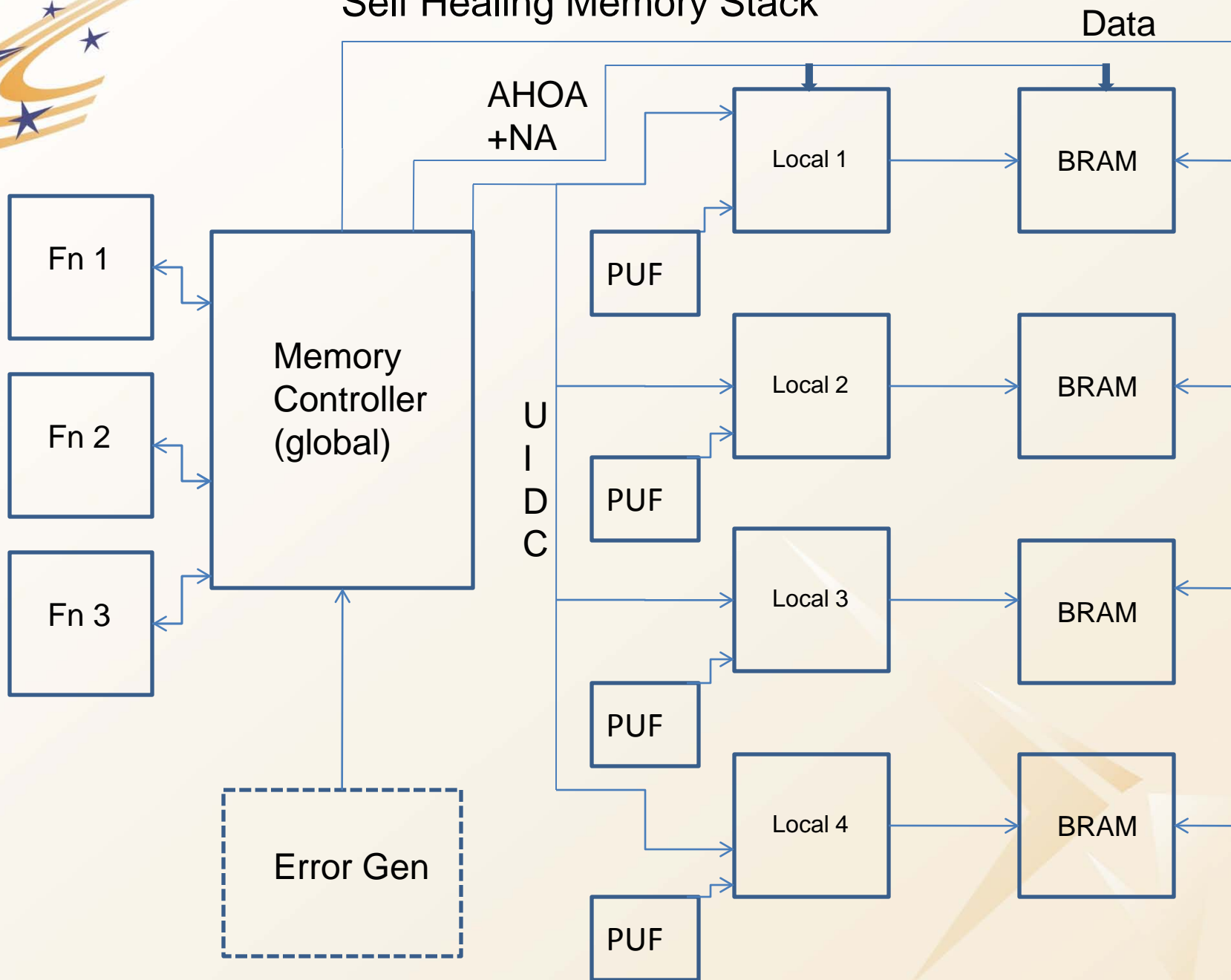



Self Healing Memory Stack

- Step 1 : Discover (initial phase : scan & mark)
- Step 2 : Coalesce (Known good die)
- Step 3 : Heal (if an error occurs)



Data Restoration

- Considering RAID (Redundant Array of Independent Disks) as Background
- RAID technology provides high levels of storage reliability for PC-class disk-drive components
- Basically data is interspersed across more than one disk
- RAID has different levels, RAID 3 or 4 ,RAID 5 etc.
- RAID 3 or 4 - striped disks with dedicated parity
- RAID 5 – striped disks with distributed parity
- Parity Data in RAID environment uses Boolean XOR fn.
- Drive 1: **01101101**
Drive 2: **11010100**
Drive 3 : parity : **01101101 XOR 11010100 = 10111001**
- If Drive 2 fails
Drive 3: **10111001**
Drive 1: **01101101**
i.e. **10111001 XOR 01101101 = 1101010**



Working on

- Since our system is inherently Sectored striping data is being considered
- N-bit odd-even parity
- Hardware feedback from the memory module that indicates a spoilt chip.
- Issues
 - Memory controller failure.
 - Write time efficiency



PLAN

- Thesis Project
- The plan is to finish the project by summer 2010